

A Comparison of Local vs. Sensory, Input-Driven, Wide Area Reactive Power Control

Jonathan W. Stahlhut, *Member IEEE*, Gerald. T. Heydt, *Fellow IEEE*, and Elias Kyriakides, *Member IEEE*

Abstract— In the evolution of wide area measurement systems (WAMS) to wide area control systems (WACS), several subsystems can be considered. One such subsystem to be considered under WACS is shunt capacitor switching strategies to provide reactive power support. Many shunt capacitors are operated using local voltage control, but WACS controlled shunt capacitors are operated remotely using a system wide strategy. A WACS control of capacitor switching is proposed based on indices that assess bus voltage magnitude and complex line flows. The switching scheme which produces operationally acceptable bus voltage magnitudes or line power flows, or a combination of the two phenomena, is used for global control of reactive power support. The differences between WACS and local control are illustrated utilizing the IEEE 57 bus system as a test bed. A strategy based on the grouping of capacitors for WACS control is illustrated and compared to local control. Results show that WACS has better results when the number of bus voltage magnitudes out of range and total system losses are considered as assessment measures of control effectiveness.

Index Terms— reactive power control, sensors, shunt capacitors, wide area control systems, wide area measurement systems.

I. INTRODUCTION

REACTIVE power supply is necessary in the reliable operation of AC power systems. Several recent power outages worldwide may have been a result of an inadequate reactive power supply which subsequently led to voltage collapse [1]. Insufficient reactive power was also an issue in the August 2003 U.S. blackout [2]. The traditional means of reactive power dispatch have been a combination of controls based on both *local* objectives (e.g., local bus voltage support) and *operator driven global* objectives (e.g., voltage support over a wide area of the system). The appearance of wide area sensory technology and its concomitant control capability suggests a renewed view of *local* versus *global* control.

Manuscript received December 4, 2006. This work was supported in part by the Cyprus Research Promotion Foundation under grant ΠΔΕ/0505/06 and the Power Systems Engineering Research Center under a grant from the National Science Foundation, EEC-0001880 in the Industry / University Cooperative Research Center program.

J. W. Stahlhut is with the Electrical Engineering Department, Arizona State University, Tempe, AZ, 85287 USA (e-mail: jonathan.stahlhut@asu.edu).

G. T. Heydt is with the Electrical Engineering Department, Arizona State University, Tempe, AZ, 85287 USA (e-mail: heydt@asu.edu).

E. Kyriakides is with the Department of Electrical and Computer Engineering, University of Cyprus, Nicosia, Cyprus (e-mail: elias@ucy.ac.cy).

In AC power networks, while active power corresponds to useful work, reactive power supports voltage magnitudes that are controlled for system reliability, voltage stability, and operational acceptability. Although active power can be transported over long distances, reactive power is difficult to transmit, since the reactance of transmission lines is often 4 to 10 times higher than the resistance of the lines. When the transmission system is at heavy loading, the active power losses in the transmission system are also high. References [3] and [4] are samples of the literature that contain discussions of these issues.

In contemporary power systems, a large number of sensory signals are available. Advances such as the utilization of synchrophasors [5] are indicative of the enhancements in sensory technology. Promotion of the placement and use of measurements has been termed “wide area measurement systems” [6]. Many of these measurements have high sample rates and are potentially suitable for control applications. Thus, the transition from WAMS to WACS may be possible [7], [8]. Key controllable components include:

- Transformer taps
- Shunt capacitors
- Shunt reactors
- Flexible AC transmission system (FACTS) controllers
- Generating units.

Contemporary practice in transmission reactive power control is discussed in [9]. The technology in place is mainly a mix of operator control and automatic local control. It appears appropriate to compare these approaches especially with a view to the assessment of effectiveness of reactive power control. A conceptual approach is proposed for shunt capacitor switching in WACS. In an actual application of WACS, a variety of different control operations are likely to be performed, but the discussion here considers only shunt capacitor switching. The local versus global control of shunt capacitors is compared on the basis of the effectiveness of voltage support and line loading. Test cases are offered to illustrate the implication of local versus global control.

II. REACTIVE POWER CONTROL

Control of reactive power in a power system is essential in avoiding possible voltage collapse and instability problems. A typical solution to control the voltages in a power system is to place reactive power sources at various places throughout a

power system. These additional reactive power sources can range from generators to shunt capacitors. Perhaps the most cost effective way in many cases to help control voltage magnitude is through the use of shunt capacitors. Local control entails the use of local bus voltage magnitude to control the shunt capacitors. If the voltage at a bus goes below a specified limit (e.g., 87%), the capacitor is switched on, thus adding additional reactive power support and raising the voltage.

Wide area control of shunt capacitors can have advantages that are not shared by locally controlled capacitors. If groups of capacitors are switched in service as opposed to an individual switching, enough reactive power support to the system might be achieved before voltage collapse occurs.

Wide area control with shunt capacitors can be achieved with the knowledge of voltage magnitude and / or generator reactive power measurements. These measurements can be either directly measured or obtained from a state estimator. A laboratory wide area voltage control algorithm by the Bonneville Power Administration can be found in [7].

Attention now turns to the assessment of the effectiveness of reactive power control. Global control of shunt capacitors can be realized in many ways. For the purposes of this study, global control is effected by the calculation of two different indices that give an indication of system voltage magnitudes and complex power line flows in the network. The proposed bus voltage magnitude index gives a measure of the deviation in system voltages from rating. The proposed voltage index is Θ_V ,

$$\Theta_V = \sum_{i=1}^{N_B} (|V_i| - 1)^2, \quad (1)$$

where $|V_i|$ is the bus voltage magnitude and N_B is the number of system busses.

The proposed complex line power flow index is based on the change in the system line flow when shunt capacitors are switched into service, and is given by,

$$\Theta_S = \frac{\sum_{i=1}^{N_L} |S_i^{w/caps} - S_i^{base}|}{\Delta Q_{inj}}, \quad (2)$$

where $S_i^{w/caps}$ is the complex power flow in line i with the switched capacitors switched on, S_i^{base} is the base case complex power flow in line i (no capacitors on), N_L is the number of system transmission assets and ΔQ_{inj} is the value of reactive power injected due to the shunt capacitors added (in MVAR) into the system. The implication of a low value of Θ_S implies transmission with low line loading and possibly low congestion.

For the purpose of assessing the effectiveness of local versus wide area control, it is necessary to assume a global control algorithm. Global control of switched capacitors is assumed to be realized by evaluating Θ_V and Θ_S as defined above and as shown in Fig. 1. For example, consider N_C shunt capacitors in the system that can be used to control reactive

power. For each one of the possible combinations of operation of these capacitors (2^{N_C} combinations), both the voltage and complex power indices are calculated for the purpose of assessing the effectiveness of local and global control. If support of the system voltage magnitudes is the objective of the control action, the capacitor switching which produces the lowest Θ_V is selected as the global control strategy. Contemporary practice is that operators enable automatic control strategies and implement manual controls. The objectives of operator actions vary with operating companies and operating conditions. If avoidance of line loading congestion is chosen as the objective of the control action, the action which produces the smallest value of Θ_S is chosen.

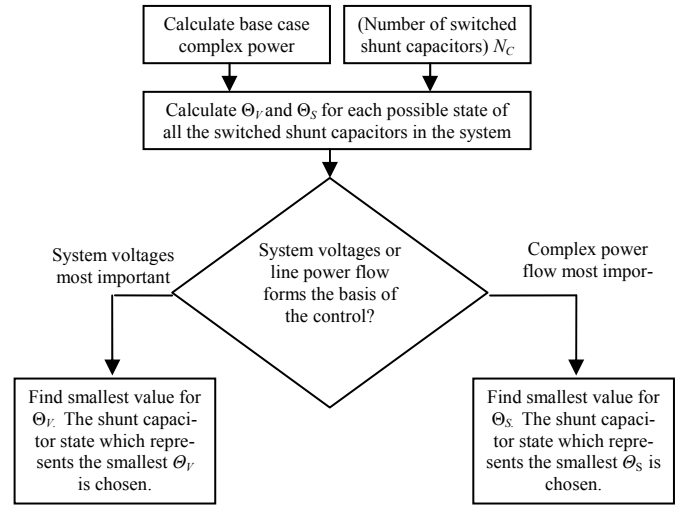

Fig. 1. Voltage and complex power flow indices for assessing the effectiveness of shunt capacitor WACS

For some cases, both the bus voltage magnitude and complex power flow indices need to be considered when reactive power support is needed. An extension of (1) and (2) into a combination index yields a new index in which both indices contribute to the global control. This combination index is Θ_C ,

$$\Theta_C = \alpha \Theta_V + (1 - \alpha) \Theta_S, \quad (3)$$

where α is a ‘contribution parameter.’ The value of α selected depends on which index, Θ_V or Θ_S , is the control objective in a given application. Fig. 2 shows the alternate WACS with the combination index included.

III. ILLUSTRATION OF THE CALCULATION OF THE VOLTAGE AND COMPLEX POWER INDEX

An illustration of the calculation of both the bus voltage magnitude and complex power flow indices is shown in this section. The IEEE 57 bus system depicted in Fig. 3 is used as a test bed [10]. For this example, five different shunt capacitors are considered. These shunt capacitors are placed at buses 25, 30, 33, 45, and 56 respectively.

Three different loading scenarios are considered. Each of these loading scenarios exemplifies different extremes in

which a power system operates. The three different loading scenarios are:

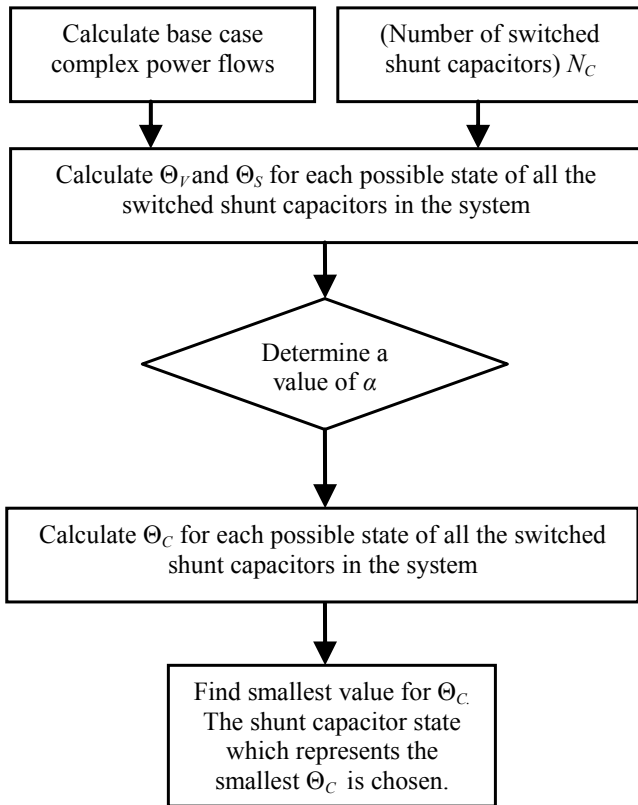

Fig. 2. Assessment of shunt capacitor WACS control using a combination index

Fig. 3. The IEEE 57 bus test bed [10]

- Case A: light system loading with power factors below 0.90
- Case B: heavy system loading with power factors higher than 0.90
- Case C: heavy system loading with power factors below 0.90.

In order to assess the effectiveness of the control scenario, consider the number of system voltage magnitudes out of range, and the total system losses. The size of the switched capacitors considered is 6 MVar. For the purposes of this study, the bus voltage magnitudes are assumed to be limited between 0.87 and 1.06 p.u.

Results for the three study cases are tabulated in Tables I-III. Since there are five capacitors to be switched, there are a total of 32 different cases to be considered. From the WACS procedure shown in Fig. 1, the global control of the capacitors for each of the cases is based on the values of the indices Θ_V or Θ_S . If bus voltage support is the objective of the control (i.e. choose the switching algorithm with the smallest value of Θ_V) the algorithm for the cases studied is:

- Case A: switch ON shunt capacitors at busses 25, 30, 33, 45, and 56
- Case B: switch ON shunt capacitors at busses 25, 30, 33, 45, and 56
- Case C: switch ON shunt capacitors at busses 25, 30, 33, 45, and 56.

If transmission congestion mitigation is the selected control strategy, the proposed switching action corresponds to the smallest value of Θ_S . Under this strategy, the switching schemes for the cases studied are:

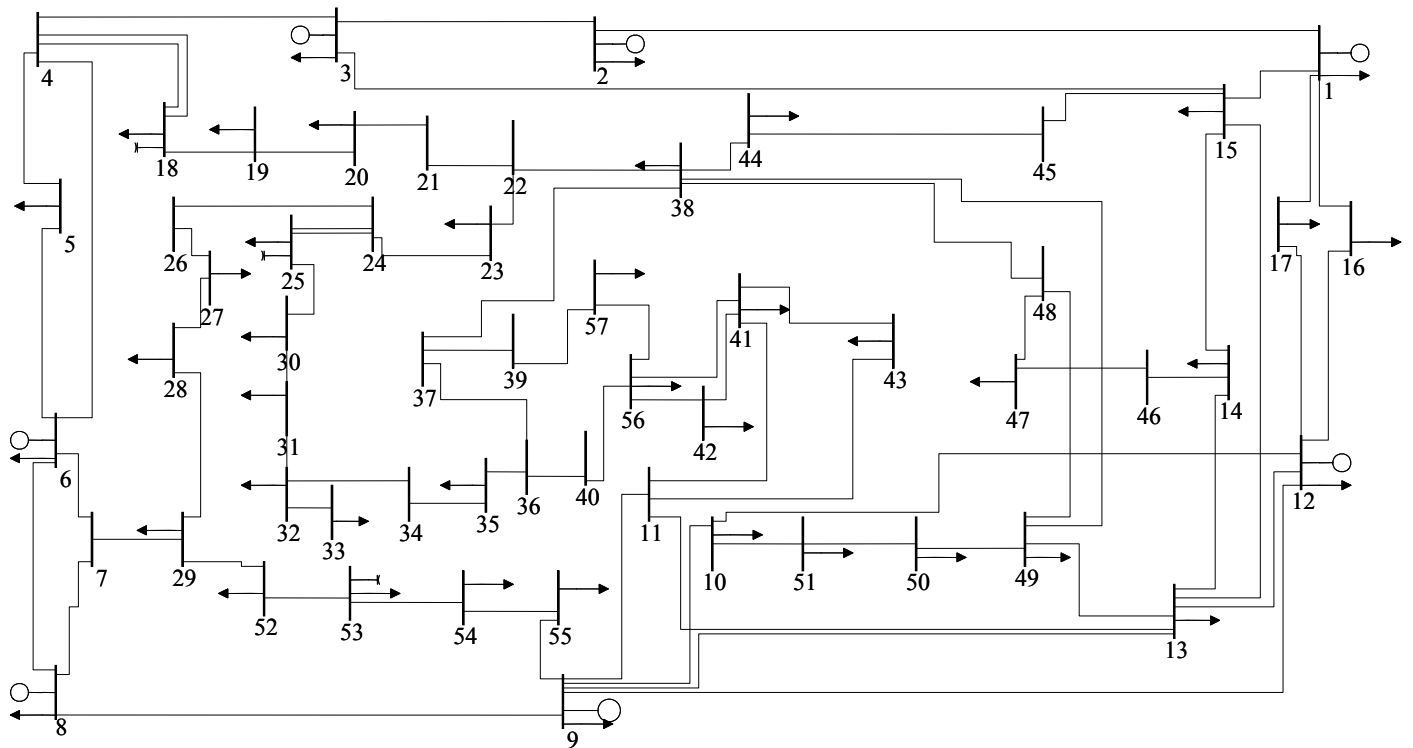

- Case A: switch ON shunt capacitors at busses 25, 45, 56
- Case B: switch ON shunt capacitors at bus 45
- Case C: switch ON shunt capacitors at bus 45.

These cases exemplify how global control can be achieved. Comparison of this WACS scheme to locally controlled shunt capacitors is shown in the next section.

TABLE I
CALCULATION OF Θ_r , Θ_s , SYSTEM LOSSES AND NUMBER OF BUS VOLTAGE MAGNITUDES OUT OF RANGE FOR CASE A

Capacitor switching scheme at bus					Case A			
25	30	33	45	56	Θ_r	Θ_s	Losses (MW)	# V out of limits
0	0	0	0	0	0.419	0.000	95.294	14
0	0	0	0	1	0.375	7.591	94.288	12
0	0	0	1	0	0.405	4.161	95.150	14
0	0	1	0	0	0.308	13.526	93.757	11
0	1	0	0	0	0.321	12.350	94.046	11
1	0	0	0	0	0.331	11.445	94.294	11
0	0	0	1	1	0.361	5.372	94.159	11
0	0	1	0	1	0.270	9.996	92.915	7
0	1	0	0	1	0.281	9.468	93.150	7
1	0	0	0	1	0.291	9.016	93.384	7
0	0	1	1	0	0.296	8.143	93.643	10
0	1	0	1	0	0.309	7.580	93.933	11
1	0	0	1	0	0.318	7.143	94.180	11
0	1	1	0	0	0.239	11.919	93.072	4
1	0	1	0	0	0.245	11.415	93.206	4
1	1	0	0	0	0.260	11.130	93.804	8
0	0	1	1	1	0.259	7.435	92.811	6
0	1	0	1	1	0.270	7.076	93.048	7
1	0	0	1	1	0.279	6.774	93.281	7
0	1	1	0	1	0.204	9.949	92.324	1
1	0	1	0	1	0.210	9.626	92.451	2
1	1	0	0	1	0.224	9.478	92.994	4
0	1	1	1	0	0.228	8.795	92.978	4
1	0	1	1	0	0.234	8.458	93.112	4
1	1	0	1	0	0.250	8.264	93.710	8
1	1	1	0	0	0.197	11.029	93.147	3
0	1	1	1	1	0.195	8.022	92.237	1
1	1	1	0	1	0.165	9.660	92.465	0
1	1	0	1	1	0.214	7.665	92.907	4
1	0	1	1	1	0.200	7.780	92.364	2
1	1	1	1	0	0.188	8.897	93.065	3
1	1	1	1	1	0.157	8.169	92.386	0

IV. LOCAL VERSUS GLOBAL CONTROL OF SWITCHED CAPACITORS

When considering implementing a WACS for shunt capacitors, it is important to compare the WACS to local control techniques. In the locally controlled scheme, only the capaci-

tors with bus voltages out of range are switched in service. For the base case evaluations, the bus voltage magnitudes that are out of range and that have shunt capacitors available are:

- Case A: busses 25, 30, 33
- Case B: busses 30, 33
- Case C: busses 25, 30, 33, 56.

TABLE II
CALCULATION OF Θ_r , Θ_s , SYSTEM LOSSES AND NUMBER OF BUS VOLTAGE MAGNITUDES OUT OF RANGE FOR CASE B

Capacitor switching scheme at bus					Case B			
25	30	33	45	56	Θ_r	Θ_s	Losses (MW)	# V out of limits
0	0	0	0	0	0.234	0.000	125.394	6
0	0	0	0	1	0.204	7.241	124.842	4
0	0	0	1	0	0.224	4.208	125.213	6
0	0	1	0	0	0.166	12.412	124.649	1
0	1	0	0	0	0.174	11.156	124.845	3
1	0	0	0	0	0.180	10.416	124.944	4
0	0	0	1	1	0.195	5.227	124.669	4
0	0	1	0	1	0.140	9.340	124.188	0
0	1	0	0	1	0.148	8.765	124.354	0
1	0	0	0	1	0.153	8.384	124.448	2
0	0	1	1	0	0.158	7.672	124.490	0
0	1	0	1	0	0.166	7.066	124.687	2
1	0	0	1	0	0.171	6.697	124.786	4
0	1	1	0	0	0.127	10.884	124.458	0
1	0	1	0	0	0.129	10.438	124.474	0
1	1	0	0	0	0.140	10.158	124.950	0
0	0	1	1	1	0.133	7.050	124.036	0
0	1	0	1	1	0.140	6.667	124.204	0
1	0	0	1	1	0.145	6.412	124.298	1
0	1	1	0	1	0.104	9.215	124.049	0
1	0	1	0	1	0.106	8.929	124.062	0
1	1	0	0	1	0.116	8.770	124.506	0
0	1	1	1	0	0.120	8.156	124.318	0
1	0	1	1	0	0.122	7.859	124.335	0
1	1	0	1	0	0.133	7.660	124.810	0
1	1	1	0	0	0.106	10.122	124.767	0
0	1	1	1	1	0.098	7.505	123.916	0
1	1	1	0	1	0.086	8.958	124.398	0
1	1	0	1	1	0.109	7.166	124.373	0
1	0	1	1	1	0.100	7.291	123.929	0
1	1	1	1	0	0.100	8.248	124.643	0
1	1	1	1	1	0.081	7.631	124.280	0

The capacitors switched on for the locally controlled cases correspond to the buses that have voltages out of range. Tables IV-VI compare the results of local and global control. After analyzing the results in Tables IV-VI for each of the three cases, it is shown that implementing global control based on the bus voltage magnitudes gives better results. The com-

parison is based on the consideration of the number of bus voltage magnitudes out of range and the total system losses.

TABLE III

CALCULATION OF Θ_r , Θ_s , SYSTEM LOSSES AND NUMBER OF BUS VOLTAGE MAGNITUDES OUT OF RANGE FOR CASE C

Capacitor switching scheme at bus					Case C			
25	30	33	45	56	Θ_r	Θ_s	Losses (MW)	# V out of limits
0	0	0	0	0	1.485	0.000	155.945	32
0	0	0	0	1	1.352	10.395	152.426	32
0	0	0	1	0	1.440	4.859	154.978	32
0	0	1	0	0	1.125	20.026	148.678	32
0	1	0	0	0	1.154	18.578	148.965	32
1	0	0	0	0	1.190	16.926	149.792	32
0	0	0	1	1	1.310	7.038	151.537	32
0	0	1	0	1	1.018	14.325	145.772	32
0	1	0	0	1	1.044	13.661	145.973	32
1	0	0	0	1	1.077	12.861	146.744	32
0	0	1	1	0	1.090	11.664	147.922	32
0	1	0	1	0	1.119	10.933	148.205	32
1	0	0	1	0	1.153	10.120	149.013	32
0	1	1	0	0	0.906	17.114	144.220	31
1	0	1	0	0	0.927	16.396	144.656	31
1	1	0	0	0	0.968	15.776	145.618	31
0	0	1	1	1	0.986	10.569	145.067	32
0	1	0	1	1	1.011	10.119	145.266	31
1	0	0	1	1	1.043	9.589	146.020	32
0	1	1	0	1	0.812	14.044	141.600	31
1	0	1	0	1	0.831	13.592	142.009	31
1	1	0	0	1	0.868	13.236	142.868	31
0	1	1	1	0	0.876	12.461	143.570	31
1	0	1	1	0	0.896	11.985	143.998	31
1	1	0	1	0	0.936	11.571	144.946	31
1	1	1	0	0	0.617	25.405	138.089	27
0	1	1	1	1	0.784	11.268	140.992	31
1	1	1	0	1	0.552	20.338	136.255	26
1	1	0	1	1	0.839	10.662	142.241	31
1	0	1	1	1	0.803	10.930	141.395	31
1	1	1	1	0	0.598	19.356	137.756	27
1	1	1	1	1	0.535	16.533	135.943	25

V. ILLUSTRATION OF GROUP VERSUS INDIVIDUAL SHUNT CAPACITOR SWITCHING

Further analysis of the WACS versus locally controlled shunt capacitors can be performed if capacitors under WACS could be considered as placed into groups. The results from the previous section basically show that switching on all the capacitors in the system produces the best results as far as the system losses and number of bus voltage magnitudes out of range are concerned. It might be advantageous to consider group capacitor switching. The concept of group capacitor control implements a different WACS control algorithm than the one discussed in Section II. Under group control, the bus-

ses in the system are grouped together, and if one bus voltage in that group goes out of range, all the capacitors in the group are switched on.

TABLE IV

COMPARISON OF LOCAL VERSUS GLOBAL CONTROL FOR CASE A

	Capacitors at bus that are switched on	Θ_r	Θ_s	Losses (MW)	# V out of limits
Local control	25, 30, 33	0.197	11.029	93.147	3
Global control based on Θ_r	25, 30, 33, 45, 56	0.157	8.169	92.386	0
Global control based on Θ_s	25,45,56	0.279	6.774	93.281	7

TABLE V

COMPARISON OF LOCAL VERSUS GLOBAL CONTROL FOR CASE B

	Capacitors at bus that are switched on	Θ_r	Θ_s	Losses (MW)	# V out of limits
Local control	30 33	0.127	10.884	124.458	0
Global control based on Θ_r	25, 30, 33, 45, 56	0.081	7.631	124.280	0
Global control based on Θ_s	45	0.224	4.208	125.213	6

TABLE VI

COMPARISON OF LOCAL VERSUS GLOBAL CONTROL FOR CASE C

	Capacitors at bus that are switched on	Θ_r	Θ_s	Losses (MW)	# V out of limits
Local control	25 30 33 56	0.552	20.338	136.255	26
Global control based on Θ_r	25, 30, 33, 45, 56	0.535	16.533	135.943	25
Global control based on Θ_s	45	1.440	4.859	154.978	32

An illustration of group switching versus individual switching of shunt capacitors in a power system is performed using the IEEE 57 bus system. For each bus load of the system, four different cases are studied:

- Case D: both active and reactive powers are twice the base case
- Case E: active power is twice and reactive power is one half of the base case
- Case F: active power is one half and reactive power is twice the base case
- Case G: both active and reactive bus powers are one half of the base case.

The intent of cases D – G is to illustrate several loading scenarios. For Cases D - G, 42 separate subcases are considered. In each of the subcases, the bus demand at a single bus is changed as indicated in the bulleted list above. Only 42 of the 57 buses in the system are available for these changes because there are 42 load buses in the test bed. Therefore a total of $4 \times 42 = 168$ subcases are studied. Bus voltage magnitudes are considered “out of limits” below 0.87 p.u. and above 1.06 p.u. The IEEE 57 bus system is broken up into four zones in which two capacitors are considered as reactive power controllable sources in each zone. The zones are:

- Zone 1: Buses 1, 2, 3, 4, 5, 6, 7, 8, 9, 12, 16, and 17
- Zone 2: Buses 26, 27, 28, 29, 53, 54, and 55

- Zone 3: Busses 18, 19, 20, 21, 22, 23, 24, 25, 30, 31, 32, 33, 34, 35, and 36
- Zone 4: Busses 37, 39, 40, 57, 56, 11, 42, 41, 43, 10, 51, 50, 49, 47, 46, 14, 13, 15, 45, 44, 48, and 38.

The two shunt capacitor banks for each zone are:

- Zone 1: Busses 1 and 9
- Zone 2: Busses 28 and 53
- Zone 3: Busses 33 and 21,
- Zone 4: Busses 48 and 56.

The value of the capacitors considered is 3 MVar.

The individual capacitor switching algorithm is performed by indicating which bus voltage magnitude is out of range, and switching the appropriate capacitor to correct the bus voltage magnitude. When the bus voltage magnitude is considered to be out of range, the capacitor that is physically closest to the violation is switched on.

Table VII compares the results for the number of system wide bus voltage magnitudes out of limits for individual and group switching control. The results from Table VII show a representation of all the 168 cases in 24 examples. Typical results from Table VII show that when considering group capacitor switching, the number of bus voltage magnitudes that are out of range decreases when compared to individual capacitor switching control. A similar conclusion can be drawn when total system losses are studied. The results for the system losses are shown in Table VIII.

TABLE VII
COMPARISON OF THE NUMBER OF VOLTAGE MAGNITUDES OUT OF RANGE BETWEEN THE BASE, INDIVIDUAL SWITCHING, AND GROUP SWITCHING CASES FOR THE IEEE 57 BUS SYSTEM

	Base Case	Individual Capacitor Switching	Group Capacitor Switching
Case D	4	3	1
	4	3	2
	4	3	1
	4	3	1
	8	6	4
	7	5	3
Case E	4	3	1
	4	3	2
	4	3	2
	5	3	3
	5	4	3
	6	3	1
Case F	4	3	1
	4	3	1
	4	3	1
	5	3	3
	5	4	3
	6	3	1
Case G	4	3	1
	4	4	1
	4	3	2
	4	3	1
	5	4	3
	6	3	1

VI. CONCLUSIONS

Wide area measurements are becoming increasingly available in contemporary power transmission systems. These measurements may be implemented in a wide area control system for transmission level, shunt capacitor switching. Two indices have been proposed for the evaluation of local versus global effectiveness of capacitors in transmission systems. A test bed study has been performed comparing local and wide area control for shunt capacitor switching. The results indicate that the wide area algorithm gives superior voltage control as well as line loading control when compared to local control. A concept of group capacitor switching has been introduced, and the group switching concept also appears to be favored as compared to local control.

TABLE VIII
COMPARISON OF TOTAL SYSTEM LOSSES BETWEEN THE BASE, INDIVIDUAL SWITCHING, AND GROUP SWITCHING CASES FOR THE IEEE 57 BUS SYSTEM

	Base Case (MW)	Individual Capacitor Switching (MW)	Group Capacitor Switching (MW)
Case D	127.78	127.00	126.75
	168.96	168.12	167.85
	141.69	140.88	140.61
	138.96	138.17	137.92
	133.08	131.58	131.10
	133.17	131.70	131.22
Case E	127.78	127.00	126.75
	168.96	168.12	167.85
	130.48	129.69	129.44
	130.80	129.98	129.72
	131.03	130.25	129.99
	132.47	131.18	130.72
Case F	127.78	127.00	126.75
	141.73	140.92	140.66
	128.77	127.98	127.74
	130.80	129.98	129.72
	131.03	130.25	129.99
	132.47	131.18	130.72
Case G	127.78	127.00	126.75
	161.66	160.79	160.53
	168.96	168.12	167.85
	128.77	127.98	127.74
	131.03	130.25	129.99
	132.47	131.18	130.72

REFERENCES

- [1] Federal Energy Regulatory Commission, *Principles for efficient and reliable reactive power supply and consumption*, Docket No. AD05-1-00, Feb. 4, 2005.
- [2] U.S-Canada Power System Outage Task Force, *Final Report on the August 14, 2003, Blackout in the United States and Canada: causes and Recommendations*, Apr. 2004.
- [3] B. F. Wollenberg, "Transmission system reactive power compensation," *IEEE Power Engineering Society Winter Meeting*, vol. 1, pp. 507 – 508, Jan. 2002.
- [4] T. J. E. Miller, *Reactive Power Control in Electric Systems*, New York: Wiley, 1982.
- [5] A. G. Phadke, B. Pickett, M. Adamiak, M. Begovic, G. Benmouyal, R. O. Burnett Jr., T. W. Cease, J. Goossens, D. J. Hansen, M. Kezunovic, L. L. Mankoff, P. G. McLaren, G. Michel, R. J. Murphy, J. Nordstrom, M. S. Sachdev, H. S. Smith, J. S. Thorp, M. Trotignon, T. C. Wang, and M. A. Xavier, "Synchronized sampling and phasor measurements for relaying and control," *IEEE Transactions on Power Delivery*, vol. 9, no. 1, pp. 442-452, 1994.
- [6] J. Y. Cai, Z. Huang, J. Hauer, and K. Martin, "Current status and experience of WAMS implementation in North America," *Asia and Pacific*

IEEE/PES Transmission and Distribution Conference and Exhibition, pp. 1-7, Aug. 2005.

- [7] C. W. Taylor, D. C. Erickson, K. E. Martin, R. E. Wilson, and V. Venkatasubramanian, "WACS-wide area stability and voltage control system: r & d and online demonstration," *Proceedings of the IEEE*, vol. 93, no. 5, pp. 892-906, May 2005.
- [8] M. La Scala, M. De Benedictis, S. Bruno, A. Grobovoy, N. Bondareva, N. Borodina, D. Denisova, A. J. Germond, and R. Cherkaoui, "Development of applications in WAMS and WACS: an international cooperation experience," *IEEE Power Engineering Society General Meeting*, June 2006.
- [9] B. F. Wollenberg, "Transmission system reactive power compensation," *IEEE Power Engineering Society Winter Meeting*, vol. 1, pp. 507-508, Jan. 2002.
- [10] R. Christie, "Power system test archive." [Online]. Available: <http://www.ee.washington.edu/research/pstca>

BIOGRAPHIES

Jonathan W. Stahlhut (S '01, M '07) is from Benton, IL. He holds the B.S. degree in Electrical Engineering from Southern Illinois University Carbondale and the Ph.D. degree from Arizona State University.

Gerald T. Heydt (S '62, M '64, SM '80, F '91) is from Las Vegas, NV. He holds the Ph.D. in Electrical Engineering from Purdue University. His industrial experience is with the Commonwealth Edison Company, Chicago, and E. G. & G., Mercury, NV. He is a member of the National Academy of Engineering. Dr. Heydt is presently the director of a power engineering center program at Arizona State University in Tempe, AZ where he is a Regents' Professor.

Elias Kyriakides (S'00, M'04) is from Nicosia, Cyprus. He received the Ph.D. degree from Arizona State University in 2003. He is a Lecturer in the Department of Electrical and Computer Engineering at the University of Cyprus. His research interests include electric machines, unit commitment, economic dispatch, and energy generation from renewable sources.